

Conductor Resistance Evaluation System

AMR



Continuous measurement of micro resistance in solder joint area and connector contact area. Efficient evaluation of the reliability of connections

The Conductor Resistance Evaluation System enables continuous measurement of resistance changes under high and low temperature cycle.

Automatic measurement, data storage and processing are operated systematically with a PC.

The system realizes accurate and effective contact reliability evaluation.

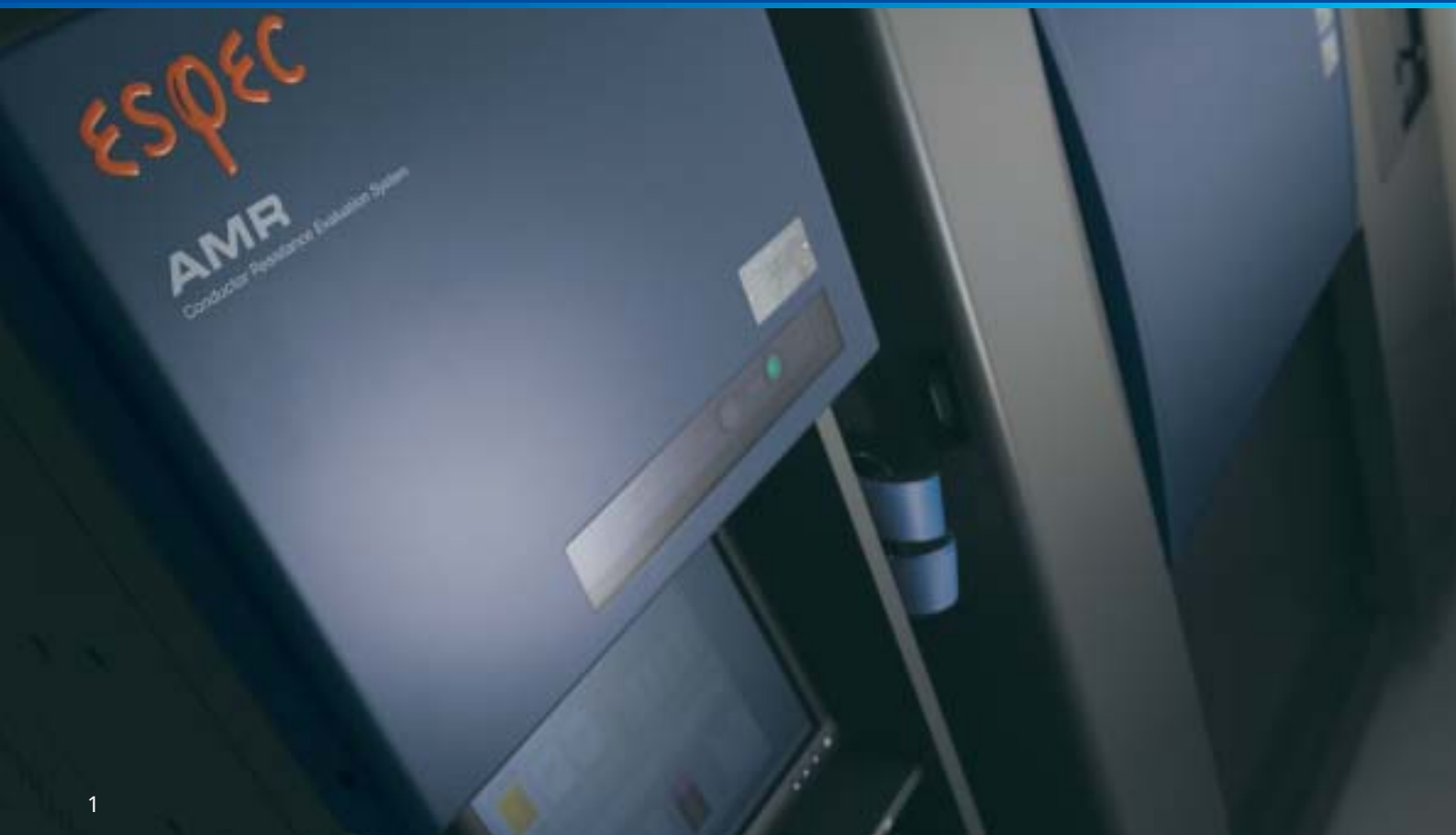

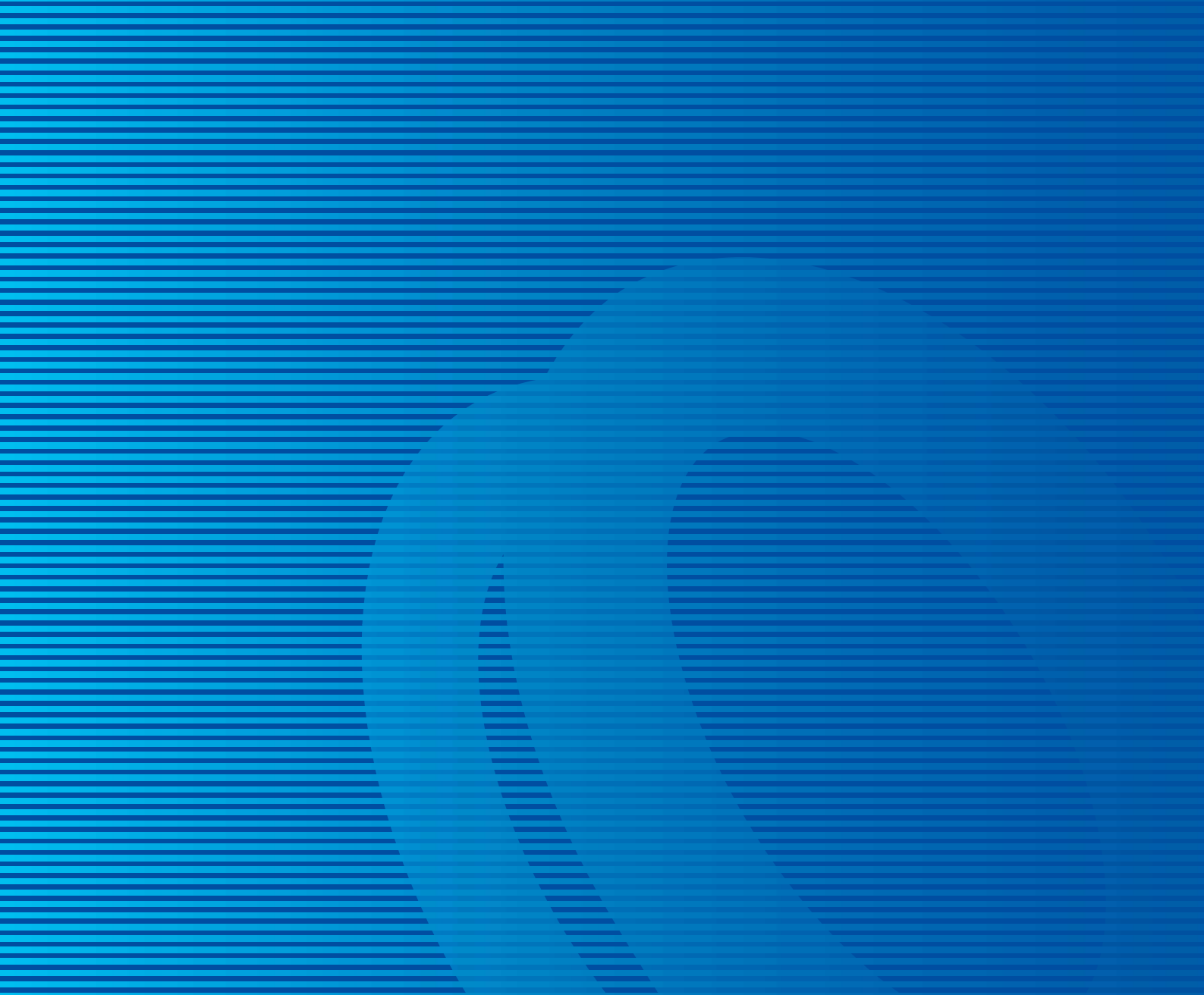

MEASUREMENT EVALUATION SYSTEMS

CONDUCTOR RESISTANCE EVALUATION SYSTEM

MAIN USE

THROUGH-HOLE CONDUCTOR EVALUATION
SOLDER-JOINT CONTACT EVALUATION
BGA, CSP SOLDER JOINT CONTACT EVALUATION
CONNECTOR CONTACT RESISTANCE EVALUATION
FPC LIFE EVALUATION
EVALUATION OF CONTACT RESISTANCE OF SWITCHES, RELAYS, etc.
EVALUATION OF LEAD-FREE SOLDER JOINTS
EVALUATION OF CONTACT RESISTANCE OF CONNECTORS, etc.
EVALUATION OF CONDUCTIVE ADHESIVES AND ANISOTROPIC CONDUCTIVE FILMS
OTHER INTERCONNECTION MATERIAL CONTACT EVALUATION

MAIN FEATURES

Unique multi-scan and international standards-compatible measurement equipment.
Direct current application and alternating current application
Absolute value evaluation and rate of change evaluation are available.
Real time measurement is enabled using a personal computer.
Data editing and data browsing are available during the measurement.
Interaction with the thermal shock chamber dramatically improves the test efficiency.

ION MIGRATION EVALUATION SYSTEM

LOW-K INSULATION CHARACTERISTIC
EVALUATION SYSTEM

LEAK CURRENT MEASUREMENT SYSTEM

CAPACITOR TEMPERATURE
PROPERTY EVALUATION SYSTEM

ELECTRO-MIGRATION EVALUATION SYSTEM

TDDb EVALUATION SYSTEM

SEMICONDUCTOR PARAMETER
AUTOMATIC EVALUATION SYSTEM

CAPACITOR LEAK CURRENT MEASUREMENT SYSTEM
FET LEAK CURRENT MEASUREMENT SYSTEM
SEMICONDUCTOR REVERSE BIAS LEAK CURRENT
MEASUREMENT SYSTEM

LSI ELECTRO-MIGRATION EVALUATION SYSTEM
GMR HEAD ELECTRO-MIGRATION RH EVALUATION SYSTEM
HIGH FREQUENCY ELECTRO-MIGRATION EVALUATION SYSTEM

WAFER LEVEL
PACKAGE LEVEL

FET(HOT-CARRIER) PROPERTY EVALUATION SYSTEM
TRANSISTOR PROPERTY EVALUATION SYSTEM

Using the international standard traceable precision instrument guarantees most accurate and compatible measurement data.

- **We have always earned our customers' confidence**

AMR is equipped with highly reliable measurement equipment and an ammeter for micro resistance meter that are designed to meet international standards in order to obtain most reliable measurement data. We offer a calibration service to maintain the equipment's accuracy (ISO / IEC 17025 compliant).

- **We offer two current applications, DC and AC**

We offer two micro electric current applications, the DC (AMR-PD) and the AC (AMR-PA), which are used to apply current to specimens when measuring the conductor resistance.

- **Measurement of a wide range of resistance from 10^{-3} to $10^6 \Omega$**

Conductor resistance values ranging from 10^{-3} to 10^6 (AMR-PD) and from 10^{-3} to 10^4 (AMR-PA) can be measured accurately at the tip of a measuring cable, using a four terminal method.

- **Multi-channel continuous measurement dramatically improves the work efficiency**

Channels can be added in 40-channel blocks from the standard 40 channels up to 280 channels (optional) depending on the tests and the number of chambers to be connected.



AMR



Measurement equipment (Agilent Technologies)

Multifunction rack that pursues ease of use improves the workability.



System rack

● Connection unit

Installing the connection unit facilitates the measurement cable connection. The connection unit can be installed in front of the rack or on the left or right side of the rack according to the work environment.

● Cable that has excellent heat- and noise-resistance characteristics

A flat cable made of Teflon is used. The excellent heat- and noise-resistance characteristics of the Teflon flat cable enable accurate measurement of micro-resistance. The end of the cable is designed to facilitate the connection to a specimen.

● Global environmental problems

Components are mounted by lead-free soldering. In addition, power consumption is reduced by 24% (in comparison with the previous model) in consideration of global environmental problems.

*except for purchased items such as PCs and measuring instruments.



Connection unit



Measurement cable (Chamber sold separately)

Tests simplified by interaction of the measurement system with various environmental test chambers.

● Interaction with the environmental test chamber

AMR can connect up to three environmental test chambers for testing. Interaction with the environmental test chamber enables temperature and humidity monitoring, management of the time schedule, and displays an alarm when a failure is detected.

● Real-time monitoring of temperature and humidity

AMR monitors and records the temp. and humid. inside the environmental test chamber. Data is recorded simultaneously with the measurement by the measurement system. The statistics processing software displays the recorded data in synchronization with the data of the resistance value.

● Safety design guaranteed by abnormality detection

If a problem occurs with the environment test equipment or AMR, the test will stop. Resetting will resume the test from where it stopped.

● Remote processing of the test data (optional)

LAN-compatible software enables remote test checking and data processing, such as from a remote office.

Additionally, we offer software licenses according to the number of users so that multiple PC monitoring is possible.



An interaction with the Thermal shock chamber

Function	Interaction with the thermal shock chamber (TSA Series)
Temperature monitoring	Reads the temperature with respect to each measurement by the measuring equipment. Finally transfers data to the CSV file.
Cycle count	Reads the cycle counting of the chamber and saves the number of failure occurrences.
Start of the test	AMR starts the test. Test automatically starts when the chamber is ready for test.
Halt of the test	When AMR halts the test, automatically halts the operations of the chamber and AMR after being exposed to high temperature.
Resumption of the test	Automatically resumes the halted cycle of the test as it is. The halt history is saved in the measurement data.
Completion of the test	Test automatically ends when the test completion condition is met.
Work temperature monitoring	Measures temperature uniformity in the chamber up to 16 channels and saves data in the CSV file on the measurement basis.
Chamber failure detection	When a failure occurs in the chamber or the measuring equipment fails to operate properly, the test automatically stops.
Data processing	Checks the obtained temperature data against the data of resistance values based on the number of cycles.

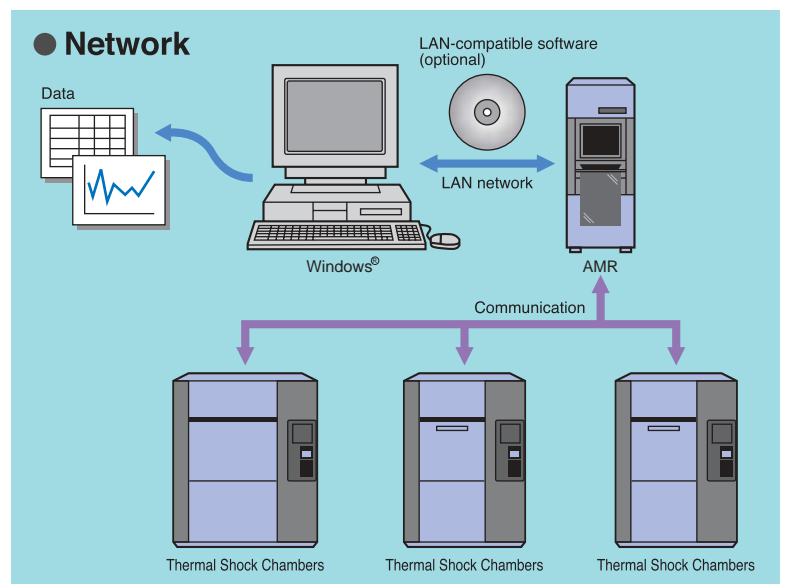

Evaluation

Two failure recognition methods are available to detect the failure in conductive resistance change at inter-connects.

● Absolute value evaluation

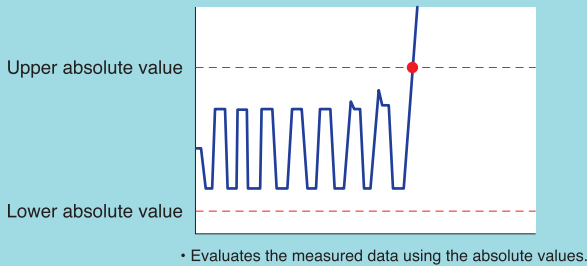

■ Absolute value setting

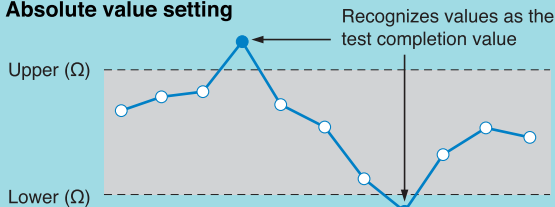

● Failure recognition using the absolute value

The measured data obtained at measurement intervals is evaluated using the preset absolute value. It will detect small change of conductive resistance change due to micro-cracks up to complete open.

You can set the absolute value in hot condition and cold condition to have separate recognition available both side of temperature. AMR will terminate the test on the channel that failure once recognized. (It can be set to resume the test too.)

● Failure recognition using the change rate (%)

This method can be used to detect small change of conductive resistance of BGA and CSP. It will compare initial value at the start point of the test and using % change to recognize the failure. It can be set on both side of hot and cold conditions.

● Rate of change evaluation

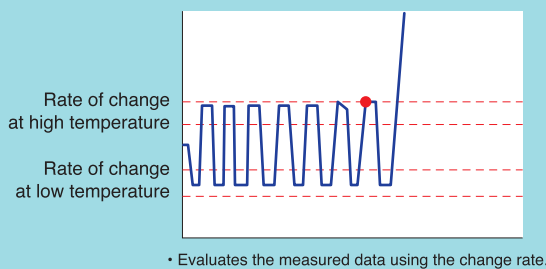

■ Rate of change setting

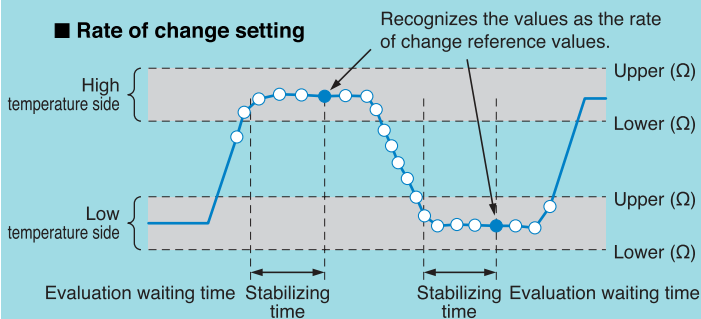

Evaluation

DC or AC measurement can be selected according to your test requirements.

● DC Measurement (AMR-PD)

Using DC current resistance to measure small voltage change and detect up to 1M ohms of resistance. It is useful to observe large change of conductive resistance such as Daisy Chain of BGA in semiconductor applications.

● AC Measurement (AMR-PA)

Using AC micro current to measure small voltage change without affected by thermal electromotive force. It is useful to observe the change of conductive resistance in contact resistance evaluations.

Evaluation item	DC application (AMR-PD)	AC application (AMR-PA)
Evaluation of lead-free solder joints		
Reliability evaluation of BGA and CSP solder ball connections		
Evaluation of bimetallic connection		
Evaluation of contact resistance of connectors, etc.		
Evaluation of contact resistance of switches, relays, etc.		
Reliability evaluation of chip capacitor connection		
Evaluation of conductive adhesive and anisotropic conductive films		

● Case example of reliability evaluation of BGA and CSP solder ball connections (Daisy chain evaluation)

● DC and AC application evaluation

In the case where signals between measured channels do not interfere with each other (in the case where communication between channels is independent of each other)

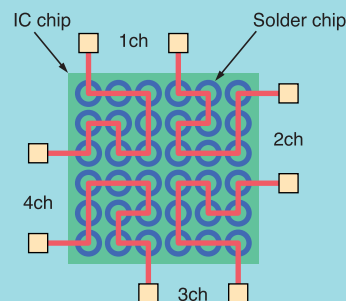

● DC application only (AMR-PD only)

In the case where the measured signals interfere with each other between channels

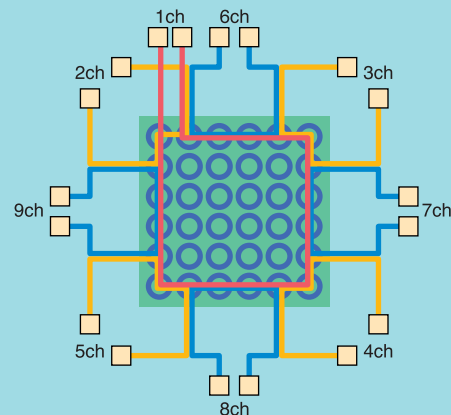

* Compatible model differs depending on the daisy chain design for BGA and CSP evaluations.

SOFTWARE

Main window*

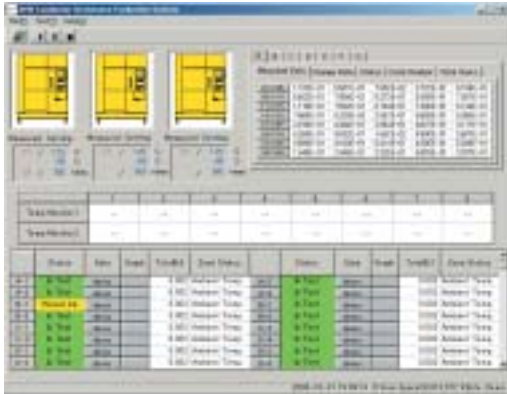

- Test monitoring
 - Real time display of the resistance value, temperature inside the chamber, channel on which a failure occurs
 - Auto link to the data processing software
 - Test control (start, stop, pause, and restart)
- * The picture above shows AMR-280-PD.

Test condition registration



On this window, you select a module, input the data file name, set the interacting chamber, output test data, input presence or absence of the leak-touch behavior mode and comment, select test channels, and specify the test condition. (Select a test condition from the test condition file.)

Registration of the test conditions



Duration and cycle of a test and measurement, measurement voltage, stress-application voltage, and limit values are saved as a test condition file. Multiple test conditions can be saved depending on the specimen and test conditions.

Graphic display



Graph can be arranged by choosing channel display, display setting, and cursor display. Graphs can be copied on a clipboard to be applied onto another software.

{ The sample graph displays resistance value with temperature on thermal shock chamber at the same time. }

Cursor function



Quick confirmation of measurement data and channel number by cursor function on graphic display.

Weibull Analysis (Optional)

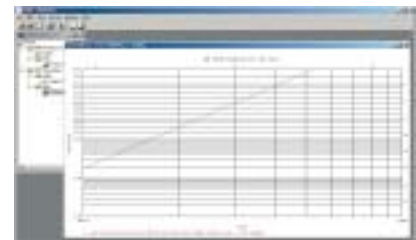

Data-processing software (with a statistical processing function) enables Weibull analysis of test data, as well as the plotting of normal probability and logarithmic-normal probability.

SYSTEM BLOCK DIAGRAM

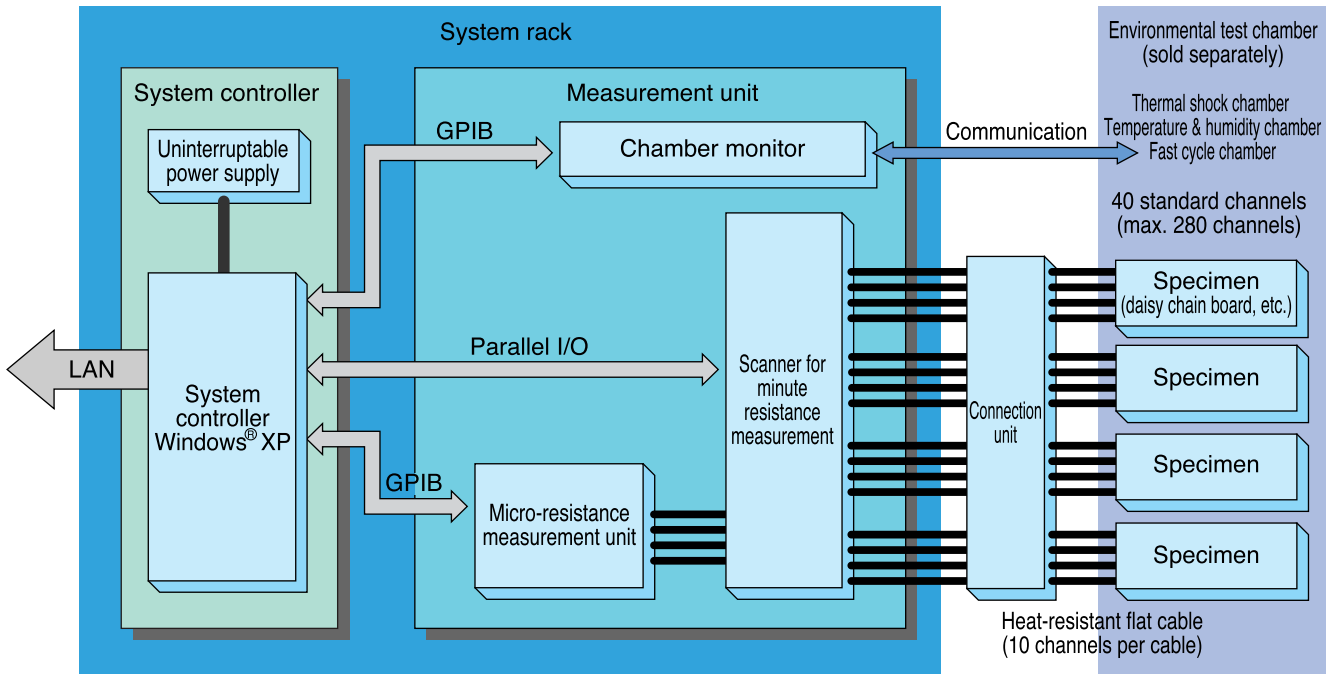

System controller

- System controller :
PC and LCD monitor for system control.
Measurement, data processing, chamber control.
- Uninterruptible power supply :
Backup power supply for system controller.
Automatically interrupts test at time of power cut.
When power recovers, test restarts from where it ended. (does not resume automatically)

Measurement unit

- Micro-resistance measurement unit :
Precisely measures resistance by 4-wire (resistance) measurements.
PD type: Equipped with 34420A made by Agilent Technologies
PA type: Equipped with 4338B made by Agilent Technologies
- Micro-resistance scanner :
40 standard channels
(Optionally, up to 280 channels can be added)
- Chamber monitor :
Allows temperature (humidity) control, monitoring, alarm control of chamber from system controller.
- Connection unit :
Relays the measurement cable.
- Heat-resistant flat cable :
Cable for measuring specimen inside test chamber

SPECIFICATIONS

Model	AMR-040-PD	AMR-040-PA	
Current application	DC application	AC application	
Channel configuration	Standard 40ch. (max. 280ch per rack)		
Control channel	A unit of 10 channels		
Software	Windows® XP		
Measurement	Measuring intervals	Minimum 3 seconds (10 channels), Variable in 3-sec. steps	
	Resistance measurement range	1×10^{-3} to $1 \times 10^6 \Omega$	1×10^{-3} to $1 \times 10^4 \Omega$
	Minimum resolution	100 $\mu\Omega$	10 $\mu\Omega$
	Measurement accuracy*	10 m Ω Measured value of $\pm 5\%$ or less	
	Measurement range	1 Ω , 10 Ω , 100 Ω , 1k Ω , 10k Ω , 100k Ω , 1M Ω , and AUTO	10m Ω , 100m Ω , 1 Ω , 10 Ω , 100 Ω , 1k Ω , 10k Ω , and AUTO
Measurement cable	Type	Heat-resistant flat cable	
	Coated material	Teflon (Temperature for continuous duty: +150°C)	
	Length	Between scanner unit and connection unit: 1.5m Beyond connection unit : 1.5m	
Connection unit	One connection unit has 40-channel connection.		
Measurement equipment	Model: 34420A (Agilent Technologies)	Model: 4338B (Agilent Technologies)	
External dimension	530W × 1750H × D940D mm		
Power supply facility	100V AC, 1 ϕ , 10.0A 120V AC, 1 ϕ , 8.3A 220V AC, 1 ϕ , 4.5A 240V AC, 1 ϕ , 4.2A		

*Value guaranteed at end of measurement cable of a standard system.

MODEL

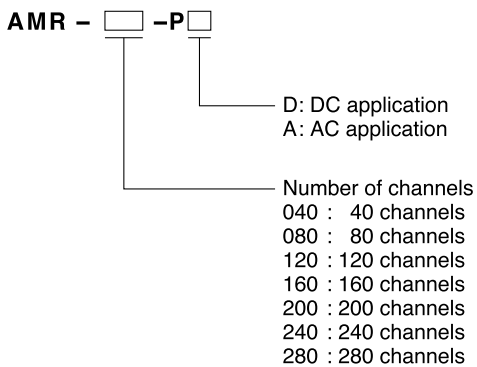

ACCESSORIES

User's manual
System controller
Uninterruptable power supply
Micro-resistance measurement unit
Setup CD
GPIB board
PPI board

OPTIONS

Additional channel (40 channel basis)

The channels can be added according to the capacity of the system (280 channels at maximum on 40 channel basis).

Specimen temperature monitor

Specimen temperature monitor measures the surface temperature of the specimen and saves the specimen surface temperature and the measured data simultaneously. The following three types are available.

- 4 point measurement type
- 8 point measurement type
- 16 point measurement type

LAN-compatible software

LAN-compatible software enables remote test checking and data processing, such as from a remote office.

* License for multiple PC monitoring requires an additional cost.

Data processing software (with statistical processing software)

Weibull analysis is installed in addition to the standard statistical processing software.

1m-extension of the non heat-resistant measurement cable

We elongate the cable that connects the measurement unit to the connecting unit. (Selectable at the time of purchase)

3m-extension of the non heat-resistant measurement cable

We extend the cable according to the installation conditions for the equipment.
* Data correction by our field service agent is necessary after the initial shipment and in the case where the lengths of all cables are changed.

1m-extension of the heat-resistant flat cable

We elongate the cable that connects the connecting unit to a specimen. (Selectable at the time of purchase)

Heat-resistant Teflon cable

Identical to the heat-resistant Teflon cable in the standard accessories
• 1.5m



Color measurement cable (150 heat-resistance)

Cables whose color varies depending on the channel
• 1.5m

Emergency stop switch

Stops the system immediately.

Communication cable

E-BUS 5, 10m

VARIOUS ENVIRONMENTAL TEST CHAMBERS SOLD SEPARATELY

Thermal Shock Chamber TSA Series



TSA series is the series that reduces the temperature recovery time, temperature heat-up time, and temperature pull-down time. TSA series has HFC refrigerant and a touch-panel that facilitates operation setting changes. TSA Series is the environment-friendly series.

Model	Temperature range	Inside dimensions (mm)
TSA 71S	High temp. chamber: +60 ~ +200 Low temp. chamber: -70 ~ 0	W410 × H460 × D370
TSA 101S		W650 × H460 × D370
TSA 201S		W650 × H460 × D670
TSA 41L		W240 × H460 × D370
TSA 71L	High temp. chamber: +60 ~ +200 Low temp. chamber: -65 ~ 0	W410 × H460 × D370
TSA 101L		W650 × H460 × D370
TSA 301L		W970 × H460 × D670

Thermal Shock Chamber TSD-100



TSD-100 is a thermal shock chamber with two zones that conform to Japanese and overseas test standards such as MIL-STD-883, JIS C 0025 and JASO-D001. With excellent temperature distribution performance, this chamber applies uniform temperature stress to specimens. Furthermore, by monitoring specimen temperature with the STT function, this chamber starts counting exposure time and switches to the next step immediately after the specimen temperature reaches a preset value, thus enabling highly accurate tests. In the temperature range between 60 °C and 150 °C, this chamber has a short return time of 15 minutes, resulting in reduction of total test time. This chamber can be used for a variety of activities, from research and development to inspection and production.

Model	Temperature range	Inside dimensions (mm)
TSD 100	High temp. chamber: +60 ~ +200 Low temp. chamber: -65 ~ 0	W710 × H345 × D410



QMS
JIS Q 9001:2000
JSAQ 004



JAB
QMS Accreditation
R001

ISO 9001/JIS Q 9001

Quality Management System Assessed and Registered

ESPEC CORP. has been assessed by and registered in the Quality Management System based on the International Standard ISO 9001:2000 (JIS Q 9001:2000) through the Japanese Standards Association (JSA).



JAB
EMS Accreditation
RE 009



051

ISO 14001 (JIS Q 14001)

Environmental Management System Assessed and Registered

ESPEC GROUP	ESPEC CORP.
	ESPEC ENGINEERING CORP.
	ESPEC KANSAI CORP.
	ESPEC ENVIRONMENTAL TEST TECHNOLOGY CENTER CORP.
	ESPEC BUSINESS CREATE CORP.

ESPEC CORP. <http://www.espec.co.jp/english>

Head Office

3-5-6, Tenjinbashi, Kita-ku, Osaka 530-8550, Japan
Tel: 81-6-6358-4741 Fax: 81-6-6358-5500

ESPEC NORTH AMERICA, INC.

Tel: 1-616-896-6100 Fax: 1-616-896-6150

ESPEC EVALUATION & TEST SYSTEMS, INC.

Tel: 1-408-592-4059 Fax: 1-408-778-4353

ESPEC EUROPE GmbH

Tel: 49-89-18939630 Fax: 49-89-189396379

ESPEC ENVIRONMENTAL EQUIPMENT (SHANGHAI) CO., LTD.

Head Office

Tel: 86-21-51036677 Fax: 86-21-63372237

BEIJING Rep. Office

Tel: 86-10-64627025 Fax: 86-10-64627036

GUANGZHOU Rep. Office

Tel: 86-20-83317826 Fax: 86-20-83317825

SHENZHEN Rep. Office

Tel: 86-755-83674422 Fax: 86-755-83674228

SUZHOU Rep. Office

Tel: 86-512-68664007 Fax: 86-512-68601994

WUXI Rep. Office

Tel: 86-510-82735036 Fax: 86-510-82735039

ESPEC TEST TECHNOLOGY (SHANGHAI) CO., LTD.

Tel: 86-21-68798008 Fax: 86-21-68798088

ESPEC (MALAYSIA) SDN. BHD.

Tel: 60-3-89451377 Fax: 60-3-89451287

Specifications are subject to change without notice due to design improvements.

Windows® is a trademark or registered trademark of Microsoft Corporation in the U.S.A. and other countries. Other corporate names and trade names mentioned in this catalog are trademarks or registered trademarks.

Printed on recycled paper.